

HF Antenna & Transceiver Selector - PA0WIT



<http://www.rsars.org.uk/ELIBRARY/docsants.htm>



The selector is located indoors on the shack desk where all the antenna and transceiver cables are presented. The unit employs 12 volt relays to switch between antenna and transceivers. The relays are arranged in two blocks and the relays in each block are selected by two rotary switches. The selector box uses a commercial SWR – Power meter (see notes on page 4).

There are also two push buttons and a changeover switch that can be used to bypass an automatic antenna tuner or remotely control the SG-237 automatic ATU from the selector box. This is normally connected to Antenna 1 input. The selector is designed to switch between 3 antennas and 4 transceivers. All S0239 connectors are grounded when they are not in use, additionally the transceiver connectors are insulated from ground to prevent stray RF damaging the receiver's from ends (see circuit on page 2)

A junction box for antenna and switching unit coax cables is located outside the house and each coax connection is protected by a lightning arrester. There is a connection to a safety earth consisting of two 4m copper pipes

Jan PA0WIT



The lightning arrester box mounted above one of the 4m copper ground pipes.

HF Antenna & Transceiver Selector - PA0WIT



<http://www.rsars.org.uk/ELIBRARY/docsants.htm>

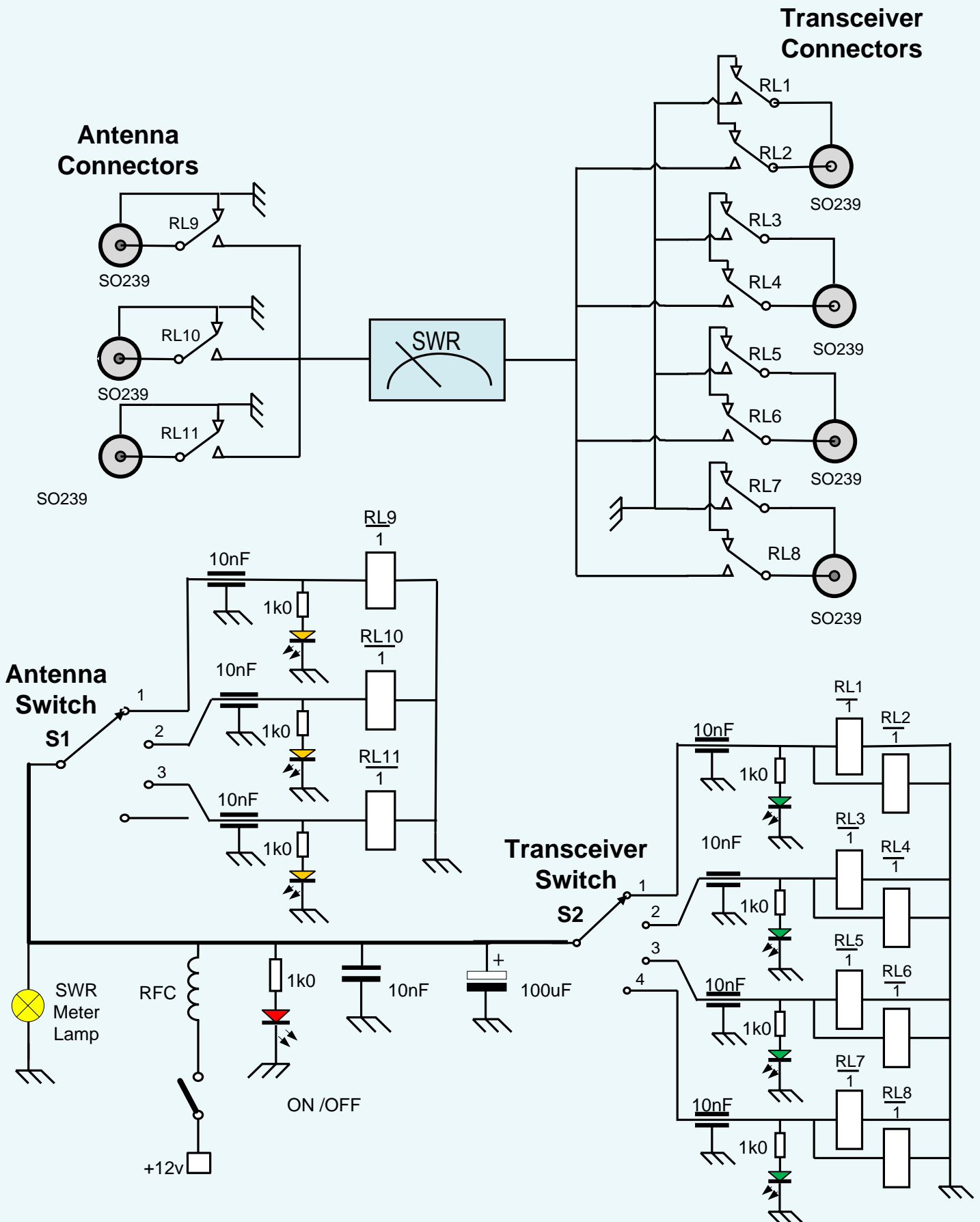



REAR VIEW OF THE SELECTOR

The metal box bolted to the chassis, that is used to screen the three vertically mounted SO239 antenna connectors, can be seen on the far left of the photograph.

Along the bottom edge of the chassis are the four transceiver SO239 connectors. These are insulated from the chassis by black plastic insulating washers.

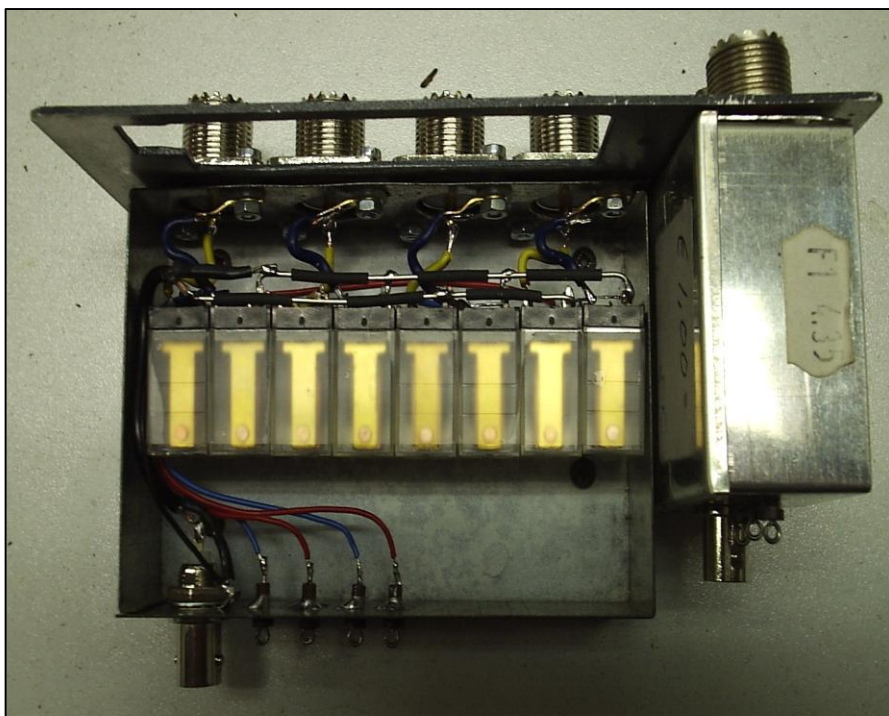

VIEW OF REAR OF THE FOUR TRANSCEIVER SO239 CONNECTORS

The right hand side of this photograph shows the rear of the antenna screening box with its BNC connector that is used to connect to the SWR measuring head's antenna side.

The four pairs of transceiver relays, that have been mounted in another screening box (lid removed for clarity) are also visible.

The four SO239 connectors are bolted through the main chassis and the transceiver relay box using insulating bushes and washers.

The Shell of each connector is connected grounding relay via a blue wire. The yellow wire connects to each SO239 centre pin.

Four 10nF decoupling capacitors and the BNC connector, which is connected to the transmitter side of the SWR sensor, pass through the lower edge of the screening box

HF Antenna & Transceiver Selector - PA0WIT



<http://www.rsars.org.uk/ELIBRARY/docsants.htm>

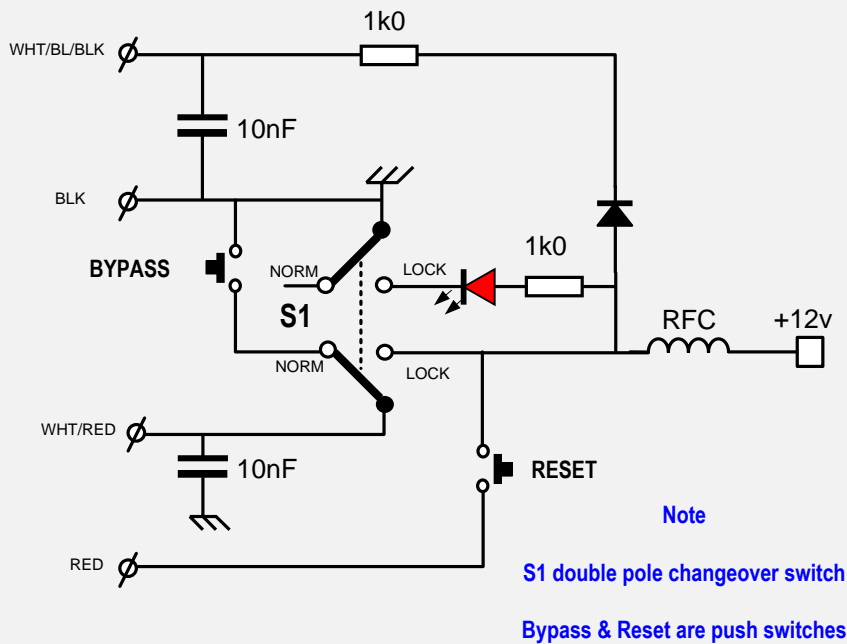

THE CIRCUIT FOR REMOTELY OPERATING THE SG237 AUTO TUNER

This is the additional circuitry that was incorporated into the selector to enable the SG237 to be operated remotely.

The changeover switch can be seen to the of the SWR meter in the lower photograph.

The push button switches are hidden from view underneath the SWR meter.

The wire colours correspond to the SG237 internal wiring.

TOP REAR VIEW OF THE INSIDE OF THE SELECTOR.

This photograph shows the rear panel with its sub-assemblies prior to final assembly to the main chassis, including a view of the wiring that has already been soldered.

The transceiver's SO239 connections to the relays are made with stiff tin plated wire with additional insulating sleeves. These should be kept as short as possible as this affects the SWR when the selector is in circuit between the transceivers and antennas.

Standard 50 ohm BNC connectors are used on the to the silver box housing the SWR sensing unit.

The black MIL Spec RG58 coax can be clearly seen on the antenna side of the SWR sensing unit.

The green and yellow LEDs on the front panel can be seen to the left of the antenna rotary switch and the SWR meter and blue Power ON/OFF push switch is visible at the bottom left of the photograph

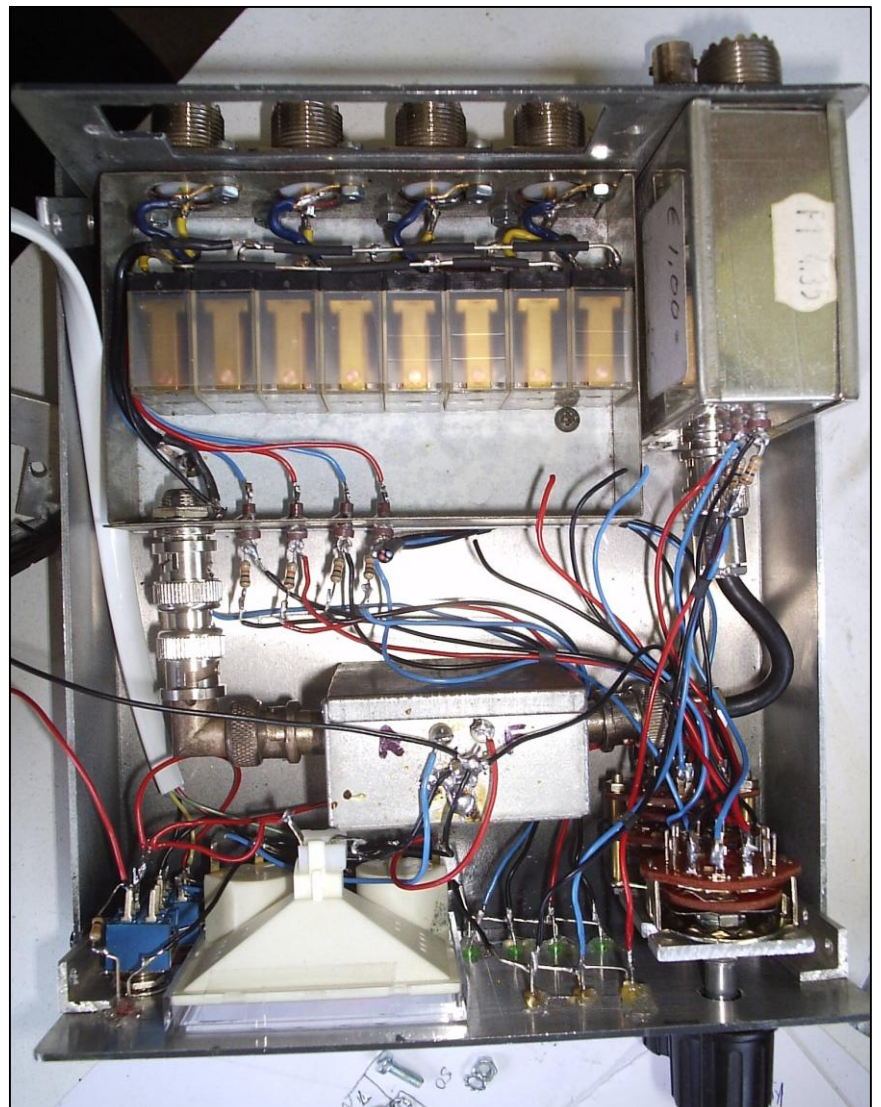

HF Antenna & Transceiver Selector - PA0WIT

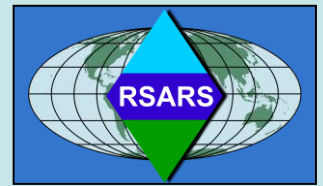

<http://www.rsars.org.uk/ELIBRARY/docsants.htm>

SELECTOR DETAILS

The idea behind the Selector was to facilitate a simple means of switching between transceivers and antennas while monitoring SWR and power output. This design enables the performance of transceivers and antennas to be easily compared.

The Main Design Features.

1. With the selector switched off, all antennas and transceiver inputs are earthed
2. When one antenna is in use, all others are earthed.
3. When one transceiver is in use, the antenna connectors of all other transceivers are shorted to earth to prevent RF damage.

The selectors inputs are used in the following way:-

The antenna 1 input is used for a 160 - 80 - 40 - 30M fan dipole,
The antenna 2 input for the 10 - 20M rotary dipole
The antenna 3 input is a dummy load.

Construction Details.

The antenna S0239 connectors are mounted directly onto the metal chassis of the selector, but the transceiver connectors are isolated from the chassis using insulating washers. This has been done to reduce the possibility of stray RF being fed into the other transceivers.

The relays used for transceiver switching are all single pole changeover, using a pair of relays for each transceiver connection, however double pole changeover relays could be employed instead. The relays are activated by rotary switches with LEDs provided to indicate the selected antenna and transceiver..

The SWR bridge and SWR / 300W power meter are commercial items obtained from :-

www.eurofrequency.de <<http://www.eurofrequency.de/>> ,

but any other bridge and meter can be used if the circuit is suitably adapted to incorporate these e.g. connector added to feed an external meter.

On the lower left of the front panel a facility has been included to remotely control an SG237 Auto Tuner, the circuit could easily be modified to accommodate other types of tuner such as the :-

LDG LDG Z-11 , MFJ-925 , Icom AH4 or Yaesu FC40 Automatic Antenna Tuners

Of course there is nothing to stop the Selector being used with manual tuners as well.

External installation on house wall.

On the outside wall is a small box with lightning arrestors. The picture on page 1 shows the coaxial cables coming out of a plastic pipe which goes underground to the antennas. All of the coax cables are connected to lightning arrestors in the box, these are earthed by the visible 4m copper pipe, which is connected to a second 4m copper pipe driven into the ground.

“With the above set up I have everything in one place and no other switches and cables laying around in the shack”.

Kind regards & best 73 de Jan PA0WIT